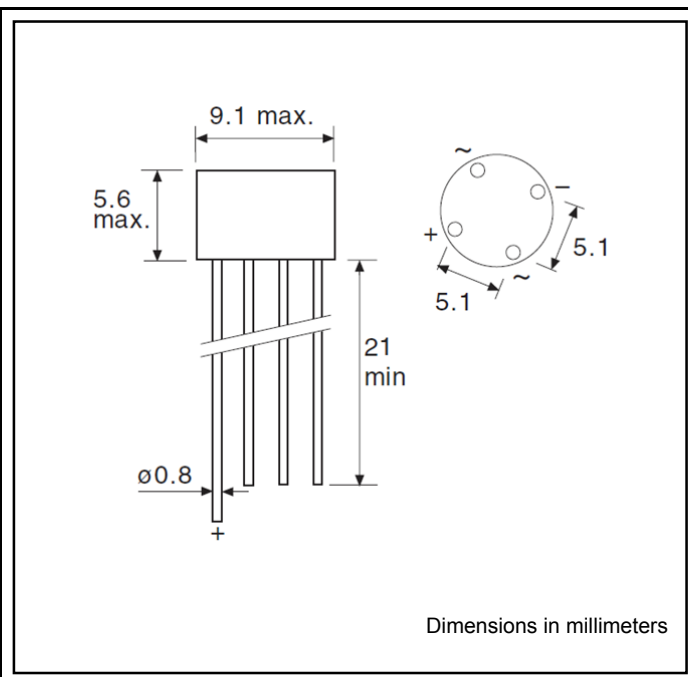

SILICON BRIDGE RECTIFIERS
VOLTAGE RANGE: 50 --- 1000 V
CURRENT: 1.5 A
FEATURES

- ◇ Rating to 1000VPRV
- ◇ Surge overload rating to 30 Amperes peak
- ◇ Ideal for printed circuit board
- ◇ Reliable low cost construction utilizing molded plastic technique results in inexpensive product
- ◇ Lead solderable per MIL-STD-250 method 2026
- ◇ Plastic material has UL flammability recognition 94V-0
- ◇ Weight: 0.050 ounces, 1.42 grams
- ◇ Glass passivated chip junctions

MAXIMUM RATINGS AND ELECTRICAL CHARACTERISTICS

Ratings at 25°C ambient temperature unless otherwise specified.

Single phase, half wave, 60 Hz, resistive or inductive load. For capacitive load, derate by 20%.

		W005	W01	W02	W04	W06	W08	W10	UNITS
Maximum recurrent peak reverse voltage	V_{RRM}	50	100	200	400	600	800	1000	V
Maximum RMS voltage	V_{RMS}	35	70	140	280	420	560	700	V
Maximum DC blocking voltage	V_{DC}	50	100	200	400	600	800	1000	V
Maximum average forward Output current @ $T_C=50^\circ\text{C}$	$I_{F(AV)}$	1.5							A
Peak forward surge current 8.3ms single half-sine-wave superimposed on rated load	I_{FSM}	50							A
Maximum instantaneous forward voltage at 1.0 A	V_F	1.0							V
Maximum reverse current @ $T_A=25^\circ\text{C}$ at rated DC blocking voltage @ $T_A=125^\circ\text{C}$	I_R	5.0 0.5							μA mA
Operating junction temperature range	T_J	- 55 ---- + 125							$^\circ\text{C}$
Storage temperature range	T_{STG}	- 55 ---- + 150							$^\circ\text{C}$

RATING AND CHARACTERISTIC CURVE *W005---W10*

FIG.1 – PEAK FORWARD SURGE CURRENT

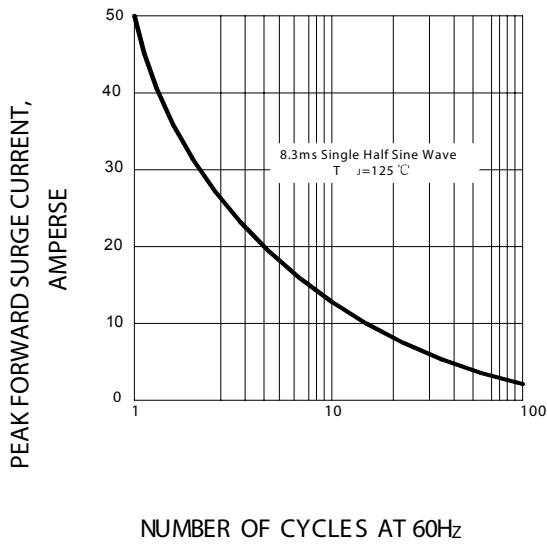

FIG.2 – FORWARD DERATING CURVE

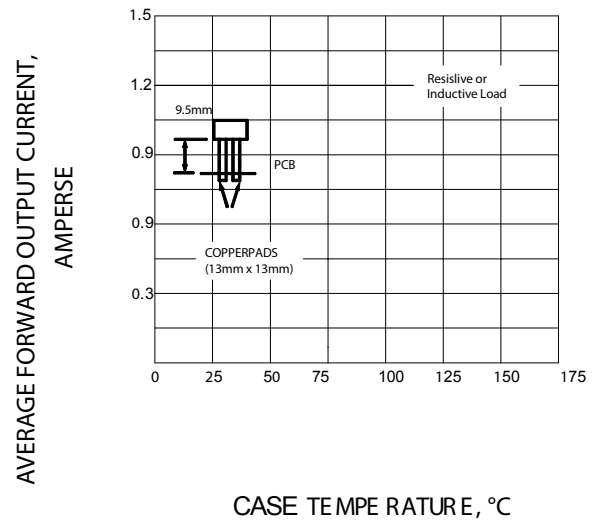

FIG.3 – TYPICAL FORWARD CHARACTERISTIC

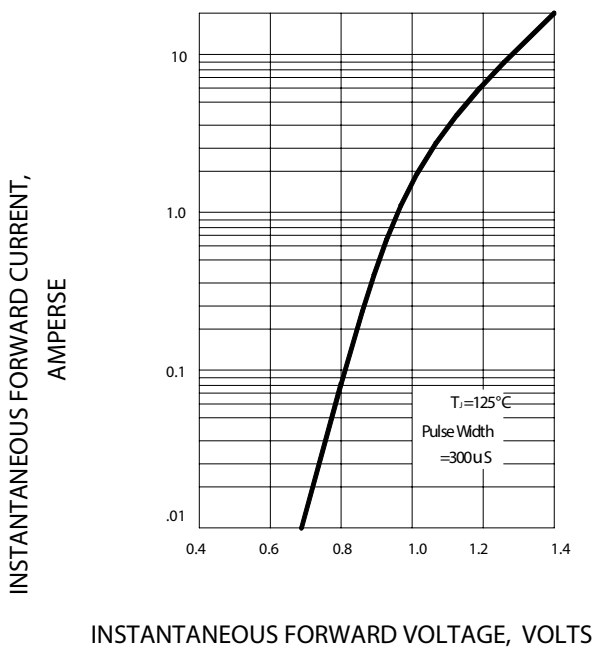

FIG.4 – TYPICAL REVERSE CHARACTERISTIC

